

Product Planning Guide

Nonproprietary - What's in it for the building owner?

Complete Ownership of Elevator System

Like leasing a vehicle, when elevator equipment is proprietary, you do not own it. You can be charged for upgrades, software updates, and accrue additional service and maintenance fees. When equipment is non-proprietary, it belongs to you and the decisions are yours to make.

Choice of Service and Maintenance Provider

Any certified elevator technician can perform service and maintenance on non-proprietary elevator equipment. You are not locked into one service and maintenance provider and have the ability to collect numerous bids, breeding competition and driving down cost on bid day.

Availability of Parts

Non-proprietary equipment manufacturers stock parts for less elevator downtime and fast lead times.

Supports Local Business

Gives the locally-vetted, independent, elevator contractors the opportunity to bid the job.

Table of Contents:

Residential Elevators

- Residential 3
- LULA 4

Hydraulic Elevators

- In-Ground Passenger 5-6
- Twin Jack Holeless 7-8
- In-Ground Freight 9-10
- Power Units 11
- Minimum Machine Room 12

Machine Room Less Elevators

- Rail Supported 13-14
- Frame Building Supported 15-16
- Building Supported 17-18
- Overslung/Cornerpost 19-20
- Minimum Control Room 21
- Minimum Stretcher Size Requirements 22

Traction

- Overhead Traction/Geared/ Gearless/Passenger 23-24

Passenger Cabs

- Standard Specifications 25
- Standard Cab Options 26
- Entrances 27

Notes

- Notes 28

Custom Projects

- Custom Projects 29-30

For Residential elevators and LULA's please refer to separate planning guides.



DEM Elevating Equipment

DEM Elevating Equipment is a family owned and operated elevator manufacturing company based in Salisbury, Maryland. DEM EE began in the early 2000's but has roots dating back to the 1930's, when the Meeks family began selling elevator parts and equipment in Wilmington, Delaware. We specialize in group 1 equipment and offer a wide range of elevator parts and components, including power units, cabs, doors, entrances, pit ladders and car top railings (to name a few). Our continued commitment to providing the best quality products has made us one of the largest, independent, non-proprietary elevator equipment manufacturers in the United States.

Our overall goal is to provide quality products and responsive customer service tailored to meet the individual needs of our valued customers. We confidently affirm that we are large enough to solve any elevator problems and can assist on custom projects while providing personal care that is the backbone of our family owned business.

We attribute over 75 years of success to our highly skilled employees, both in the office and on our shop floor. We take pride in promoting safety, quality and value. We welcome the opportunity to work with you on any and all of your vertical transportation needs and are proud to manufacture our equipment in the USA with 100% certified welders and skilled tradesmen.



Characteristics

- 950 lb capacity
- 40 FPM nominal car speed
- Up to 6 stops with 50 feet of floor to floor travel
- Minimum pit depth of 10 inches required (12" recommended)
- Minimum overhead clearance of 8'-0" required (9'-6" recommended)
- Up to 15 square feet interiors cab sizes available (12 ft standard)

Options

- Cabs available in a wide variety of finishes and other options
- Accordion cab doors in hardwoods, custom stain & lacquer finish aluminum, clear or bronze acrylic panels
- Recessed telephone cabinet
- Automatic car door operator
- Polished stainless steel, brushed brass, or polished brass pushbutton faceplate & handrail finishes

Equipment

- 1:2 Roped hydraulic drive
- (2) 3/8" diameter hoist cables
- 1-Stage hydraulic piston & cylinder w/self-adjusting seal
- Heavy duty cantilevered designed car sling w/roller guide shoes
- 8 lb/ft steel tee guide rail system
- 220 volt single phase power supply
- Vibration free submersible pump/motor assembly (3 or 5 HP motor)
- 2-Speed control valve and constant down speed regulation

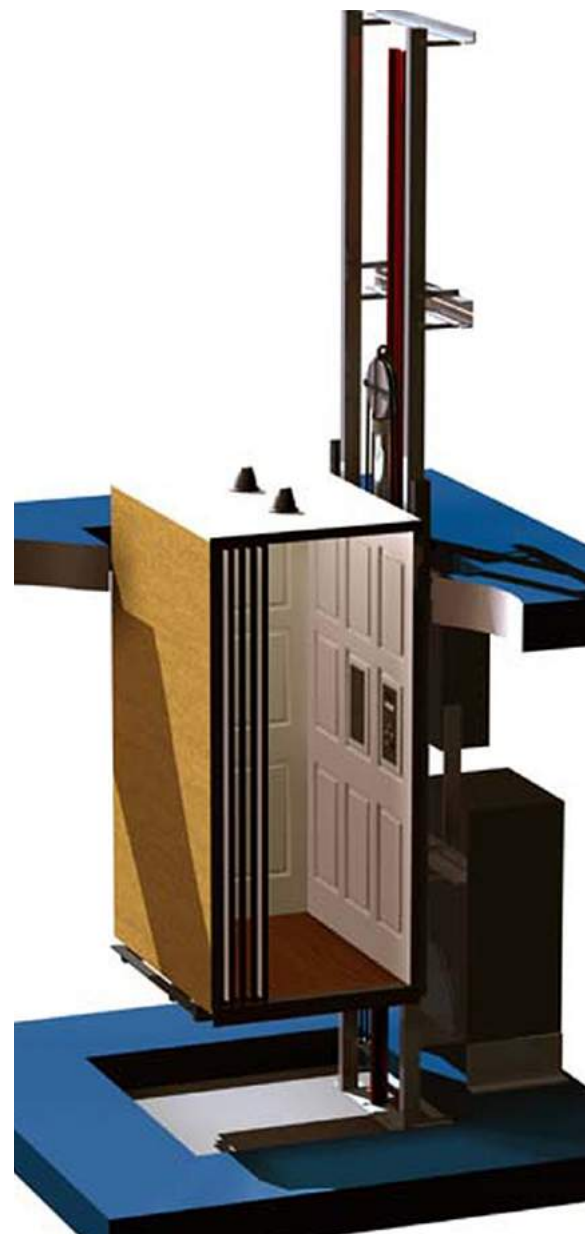

Refer to Residential Planning Guide for more information

Equipment Overview

The Olympic LULA utilizes a 1:2 roped hydraulic drive system powered by a 5HP Submersible power unit. The specifications below are standard dimensions for the initial planning stages (prior to construction).

Capabilities

- Travel: Up to 25 ft.
- Stops: Up to 4 stops
- Capacity: 1,400lb
- Speed 30 FPM

Basic Requirement

- Typical Overhead New Construction: 11'- 2"
- Minimum Overhead Existing Building: 9' - 6"
- Minimum Pit Depth With Pit Prop Device: 14"
- Minimum Pit Depth Without Pit Prop Device: 42"
- Machine Room Within 50 ft

Roped Hydraulic Drive

- 1:2 Roped Hydraulic
- Motor: 5 HP Submersible
- Valve: Blain EV100
- Power Supply Single Phase: 220VAC
- Power Supply Three Phase: 208VAC
- Power Supply Three Phase 460VAC

Standard Features

Our standard package includes everything you need to install your LULA package. Although we offer custom sizes and optional features, the following items are included in the standard Olympic LULA package.

Cab & Entrances

- Flush Laminated Shell Walls
- Painted Steel Canopy With Lexan Diffused Panels
- #4 Brushed Stainless Steel Handrail
- #4 Brushed Stainless Steel Entrance Frame
- #4 Brushed Stainless Steel 2 Speed Doors
- #4 Brushed Stainless Steel Car Operating Panel
- Aluminum Sill(s)
- Car Top inspection Station

Fixtures

- #4 Brushed Stainless Steel Hall Stations
- Digital Position Indicator with Directional Arrows in Car
- ADA Hands Free In-Car Telephone

Safety & Code Features

- Overspeed Valve
- Automatic Cab Lighting
- Emergency Cab Lighting
- Infrared Door Protection System
- Emergency Battery Lowering
- Oil Temperature Protection
- Phone Line Loss Protection (If Applicable)
- Keyed Emergency Stop Switch And Alarm Button
- Braille Tags
- Fire Service Phase 1



Refer to LULA Planning Guide for more information



IN-GROUND CAR TYPE SUMMARY

This is the traditional elevator application that has been used for many years. The single hydraulic jack is located in the ground directly under the platform. The jack is protected from the ground using a sealed PVC liner.

Advantages

- Material cost is less expensive than all other car types
- Easiest to install
- Available in low and high capacity applications
- Pit depth and overhead dimensions are typically always standard, not requiring any extended dimensions, even though the travel can be upwards to several landings.

Disadvantages

- Jack is located underground and oil contamination is remotely possible, though the PVC liner is providing protection between the cylinder and the actual soil.
- Geographic areas which experience seismic activity will present the greatest risk of oil contamination
- The jack (single stage) must go down into the ground the same distance as the travel
- Drilling a jack hole can be expensive, depending upon the ground conditions



Low Capacity Standard Dimension & Specification Chart

Capacity (lbs.)	Openings F=Front R=Rear	Door Type and Width	Platform Size W x D (min)	Hoistway Depth Platform Plus	Hoistway Size W x D (min)	Clear Inside W x D (min)	Running Clearance Sill/Plat	Sill Depth Req'd'
2100	F	1SP 36"	6'-0" x 5'-1"	9"	7'-4" x 5'-10"	5'-8" x 4'-3"	1"	5"
2100	F&R	1SP 36"	6'-0" x 5'-8"	12"	7'-4" x 6'-8½"	5'-8" x 4'-4"	1"	5"
2500	F	1SP 42"	7'-0" x 5'-1"	9"	8'-4" x 5'-10"	6'-8" x 4'-3"	1"	5"
2500	F&R	1SP 42"	7'-0" x 5'-8"	12"	8'-4" x 6'-8½"	6'-8" x 4'-4"	1"	5"
3000	F	1SP 42"	7'-0" x 5'-6"	9"	8'-4" x 6'-3"	6'-8" x 4'-8"	1"	5"
3000	F&R	1SP 42"	7'-0" x 5'-11"	12"	8'-4" x 6'-11½"	6'-8" x 4'-7"	1"	5"
3500	F	1SP 42"	7'-0" x 6'-3"	9"	8'-4" x 7'-0"	6'-8" x 5'-5"	1"	5"
3500	F&R	1SP 42"	7'-0" x 6'-9"	12"	8'-4" x 7'-9½"	6'-8" x 5'-5"	1"	5"
3500H	F	2SP 42"	5'-4" x 8'-4"	11"	6'-8" x 9'-3"	5'-0" x 7'-4"	1"	6 ½"
3500H	F&R	2SP 42"	5'-4" x 9'-0"	15"	6'-8" x 10'-3½"	5'-0" x 7'-4"	1"	6 ½"
4000	F	1SP 48"	8'-0" x 6'-3"	9"	9'-4" x 7'-0"	7'-8" x 5'-5"	1"	5"
4000	F&R	1SP 48"	8'-0" x 6'-9"	12"	9'-4" x 7'-9½"	7'-8" x 5'-5"	1"	5"
4000H	F	2SP 48"	6'-0" x 8'-5"	11"	7'-4" x 9'-3"	5'-8" x 7'-5"	1"	6 ½"
4000H	F&R	2SP 48"	6'-0" x 9'-1"	15"	7'-4" x 10'-4½"	5'-8" x 7'-5"	1"	6 ½"
4500H	F	2SP 48"	6'-0" x 8'-9"	11"	7'-4" x 9'-7"	5'-8" x 7'-9"	1"	6 ½"
4500H	F&R	2SP 48"	6'-0" x 9'-6"	15"	7'-4" x 10'-9½"	5'-8" x 7'-10"	1"	6 ½"
5000H	F	2SP 48"	6'-0" x 9'-8"	11"	7'-6" x 10'-7"	5'-8" x 8'-8"	1"	6 ½"
5000H	F&R	2SP 48"	6'-0" x 10'-4"	15"	7'-6" x 11'-7½"	5'-8" x 8'-8"	1"	6 ½"

OVERHEAD REQUIRED QUICK CALCULATION

- Regardless of what the travel is, the standard minimum overhead is 12'-6". Consult your DEM EE representative if your overhead is less than 12'-6".
- **For seismic zone 2 or greater application - increase hoistway width 2"**
- For 1¼" running clearance, increase hoistway depth ½"

Pit Depth	4'-0"
Piston Bottom Undertravel	12"
Car Speed	Up To 150 FPM
Cab Height	8'-0"
Piston Top Overtravel	5"

APPROXIMATE CLEAR INSIDE DIMENSIONS OF CAB

- Width** = Platform Width less 4"
- Depth = Front Open Only**
SSSO & CO Doors = Platform Depth Less 10"
2SSO Doors = Platform Depth less 12"
- Depth = Front & Rear Open**
SSSO & CO Doors = Platform Depth Less 16"
2SSO Doors = Platform Depth less 20"
- D.B.G. (Distance Between Guides)**
Platform Width plus 3 ¼" 12# / 15# rail depth= 3 ½"

Hoistway dimensions shown are not for final construction purposes. National & Local code years and variations may affect sizes shown. All dimensions should be verified with DEM Elevating Equipment prior to construction.

TWIN JACK HOLELESS CAR TYPE SUMMARY

This design uses (2) jacks, one on each side of the car, positioned between the platform and the hoistway wall. Single stage jacks are used for low travel, typically on 2 stop cars up to 14 ft. Two stage jacks are used for travel up to 28 to 30 feet (typically 3 to 4 stops). Higher Travel 3 Stage Telescopic Jack options available upon request.

Advantages

- Jacks are located above ground, thereby eliminating the need to drill a jack hole and eliminating the risk of oil contamination
- Accommodates low and high capacity cars

Disadvantages

- Travel is typically restricted to a 2 to 4 stop application.
- Depending upon the travel, an extended overhead may be required to fit the jacks into the hoistway elevation
- Hoistway width requirement may also be a little greater than an in-ground car type for high capacity application

For 1¼" running clearance, increase hoistway depth ½".

Contact DEM Elevating Equipment for required hoistway width for Telescopic or Roped arrangements.



Capacity (lbs.)	Openings F=Front R=Rear	Door Type and Width	Platform Size Wx D (min)	Hoistway Depth Platform Plus	Hoistway Size Wx D (min)	Clear Inside W x D (min)	Running Clearance Sill/Plat	Sill Depth Req'd"
2100	F	1SP 36"	6'-0" x 5'-1"	9"	7'-4" x 5'-10"	5'-8" x 4'-3"	1"	5"
2100	F&R	1SP 36"	6'-0" x 5'-8"	12"	7'-4" x 6'-8½"	5'-8" x 4'-4"	1"	5"
2500	F	1SP 42"	7'-0" x 5'-1"	9"	8'-4" x 5'-10"	6'-8" x 4'-3"	1"	5"
2500	F&R	1SP 42"	7'-0" x 5'-8"	12"	8'-4" x 6'-8½"	6'-8" x 4'-4"	1"	5"
3000	F	1SP 42"	7'-0" x 5'-6"	9"	8'-4" x 6'-3"	6'-8" x 4'-8"	1"	5"
3000	F&R	1SP 42"	7'-0" x 5'-11"	12"	8'-4" x 6'-11½"	6'-8" x 4'-7"	1"	5"
3500	F	1SP 42"	7'-0" x 6'-3"	9"	8'-4" x 7'-0"	6'-8" x 5'-5"	1"	5"
3500	F&R	1SP 42"	7'-0" x 6'-9"	12"	8'-4" x 7'-9½"	6'-8" x 5'-5"	1"	5"
3500H	F	2SP 42"	5'-4" x 8'-4"	11"	6'-8" x 9'-3"	5'-0" x 7'-4"	1"	6 ½"
3500H	F&R	2SP 42"	5'-4" x 9'-0"	15"	6'-8" x 10'-3½"	5'-0" x 7'-4"	1"	6 ½"
4000	F	1SP 48"	8'-0" x 6'-3"	9"	9'-4" x 7'-0"	7'-8" x 5'-5"	1"	5"
4000	F&R	1SP 48"	8'-0" x 6'-9"	12"	9'-4" x 7'-9½"	7'-8" x 5'-5"	1"	5"
4000H	F	2SP 48"	6'-0" x 8'-5"	11"	7'-4" x 9'-3"	5'-8" x 7'-5"	1"	6 ½"
4000H	F&R	2SP 48"	6'-0" x 9'-1"	15"	7'-4" x 10'-4½"	5'-8" x 7'-5"	1"	6 ½"
4500H	F	2SP 48"	6'-0" x 8'-9"	11"	7'-4" x 9'-7"	5'-8" x 7'-9"	1"	6 ½"
4500H	F&R	2SP 48"	6'-0" x 9'-6"	15"	7'-4" x 10'-9½"	5'-8" x 7'-10"	1"	6 ½"
5000H	F	2SP 48"	6'-0" x 9'-8"	11"	7'-6" x 10'-7"	5'-8" x 8'-8"	1"	6 ½"
5000H	F&R	2SP 48"	6'-0" x 10'-4"	15"	7'-6" x 11'-7½"	5'-8" x 8'-8"	1"	6 ½"

OVERHEAD REQUIRED - QUICK CALCULATIONS

SINGLE STAGE JACKS

UP to 100 FPM:
 Pit Depth = 4'-0"
 Overhead = 12'-6"
 Top Over Travel = 3.5"
 Bottom Over Travel = 5.0"
 Max. Travel = 13'-10"
 Max. "Overall" Cab Height = 8'-6"

101-125 FPM:

Pit Depth = 4'-0"
 Overhead = 12'-6"
 Top Over Travel = 4.25"
 Bottom Over Travel = 7.25"
 Max. Travel = 13'-4"
 Max. "Overall" Cab Height = 8'-6"

TWO STAGE JACKS

UP to 100 FPM:
 Pit Depth = 4'-0"
 Overhead = 12'-6"
 Top Over Travel = 9"
 Bottom Over Travel = 7"
 Max. Travel = 24'-4"
 Max. "Overall" Cab Height = 8'-2"

101-125 FPM:

Pit Depth = 4'-0"
 Overhead = 12'-10"
 Top Over Travel = 11.0"
 Bottom Over Travel = 9.0"
 Max. Travel = 24'-4"
 Max. "Overall" Cab Height = 8'-2"

For seismic zone 2 or greater application, increase hoistway width 2".

APPROXIMATE CLEAR INSIDE DIMENSIONS OF CAB

Width = Platform Width less 4"
Depth = Front Open Only
 SSSO & CO Doors = Platform Depth Less 10"
 2SSO Doors = Platform Depth less 12"
Depth = Front & Rear Open
 SSSO & CO Doors = Platform Depth Less 16"
 2SSO Doors = Platform Depth less 20"
D.B.G. (Distance Between Guides) =
 Platform Width plus 3 ¼" 12# / 15# rail depth= 3 ½"

* Consult factory for required hoistway width for telescopic jack application

Hoistway dimensions shown are not for final construction purposes. National & Local code years and variations may affect sizes shown. All dimensions should be verified with DEM Elevating Equipment prior to construction.



IN-GROUND FREIGHT SUMMARY

Freight elevators are typically designed to meet specific building/operation needs. The "standard" sizes are for general reference as a help with planning. We can custom design your freight elevator to your specific size requirements.

Custom Sizes

- Contact your DEM Elevating Equipment representative to discuss your specific requirements.
- Holeless Hydraulic & Traction Options available upon request



Class A: General Freight Loading

- Where no item including loaded truck weighs more than 1/4 rated capacity.
- Rating not less than 50 lb/ft² (240 kg/m²)

Class B: Motor Vehicle Loading

- Automobiles, trucks, buses.
- Rating not less than 30 lb/ft² (145 kg/m²)

Class C1: Industrial Truck Loading

- Where truck is carried. This loading applies where concentrated load including truck is more than 1/4 rated capacity but carried load does not exceed rated capacity.
- Rating not less than 50 lb/ft² (240 kg/m²)

Class C2: Industrial Truck Loading

- Where truck is not carried, but is used for loading and unloading. This loading applies where concentrated load including truck is more than 1/4 rated capacity but carried load does not exceed rated capacity. This loading also applies where increment loading is used, but maximum load on car platform during loading or unloading does not exceed 150% of rated load.
- Rating not less than 50 lb/ft² (240 kg/m²)

Class C3: Concentrated Loading

- No truck used, but load increments are more than 1/4 rated capacity. Carried load must not exceed rated capacity.
- Rating not less than 50 lb/ft² (240 kg/m²)

Standard Dimension & Specification Chart Using Regular Bi-Parting Power Doors

Capacity (lbs.)	Openings F=Front R=Rear	Clear Door Width	Platform Size W x D (min)	Hoistway Depth Platform Plus	Hoistway Size W x D (min)	Clear Inside W x D (min)	Minimum Platform to Side Wall
Class A & C Loading							
4000	F	5'-8"	6'-0" x 8'-0"	8"	7'-8" x 8'-8"	5'-8" x 7'-5"	10"
4000	F&R	5'-8"	6'-0" x 8'-0"	10"	7'-8" x 8'-10"	5'-8" x 7'-4"	10"
5000	F	6'-8"	7'-0" x 10'-0"	8"	8'-10" x 10'-8"	6'-8" x 9'-5"	11"
5000	F&R	6'-8"	7'-0" x 10'-0"	10"	8'-10" x 10'-10"	6'-8" x 9'-4"	11"
6000	F	8'-0"	8'-4" x 10'-0"	8"	10'-2" x 10'-8"	8'-0" x 9'-5"	11"
6000	F&R	8'-0"	8'-4" x 10'-0"	10"	10'-2" x 10'-10"	8'-0" x 9'-4"	11"
8000	F	8'-0"	8'-4" x 12'-0"	8"	10'-2" x 12'-8"	8'-0" x 11'-5"	11"
8000	F&R	8'-0"	8'-4" x 12'-0"	10"	10'-2" x 12'-10"	8'-0" x 11'-4"	11"
10000	F	10'-0"	10'-4" x 14'-0"	8"	12'-2" x 14'-8"	10'-0" x 13'-5"	11"
10000	F&R	10'-0"	10'-4" x 14'-0"	10"	12'-2" x 14'-10"	10'-0" x 13'-4"	11"
12000	F	12'-0"	12'-4" x 16'-0"	8"	14'-4" x 16'-8"	12'-0" x 15'-5"	12"
12000	F&R	12'-0"	12'-4" x 16'-0"	10"	14'-4" x 16'-10"	12'-0" x 15'-4"	12"
15000	F	12'-0"	12'-4" x 18'-0"	8"	14'-4" x 18'-8"	12'-0" x 17'-5"	12"
15000	F&R	12'-0"	12'-4" x 18'-0"	10"	14'-4" x 18'-10"	12'-0" x 17'-4"	12"
Class B Motor Vehicle Loading							
8000	F	9'-0"	9'-4" x 22'-0"	8"	11'-2" x 22'-8"	9'-0" x 21'-5"	11"
8000	F&R	9'-0"	9'-4" x 22'-0"	10"	11'-2" x 22'-10"	9'-0" x 21'-4"	11"
10000	F	10'-0"	10'-4" x 24'-0"	8"	12'-2" x 24'-8"	9'-0" x 23'-5"	11"
10000	F&R	10'-0"	10'-4" x 24'-0"	10"	12'-2" x 24'-10"	10'-0" x 23'-4"	11"

Door, Cab and car gate heights

The freight car door height is the same height as the clear inside cab height (typically minimum of 8'-0"). The standard (typical) vertical car gate is 1-section 6'-0" high, sliding straight up to clear the cab height.

APPROXIMATE CLEAR INSIDE DIMENSIONS OF CAB

Width = Platform Less 4"

Depth = Front Open Only
 Single-section gate = Platform Less 6 1/2"
 Two-section gate = Platform less 8 1/2"

Depth = Front & Rear Open
 Single-section gate = Platform Less 8 1/2"
 Two-section gate = Platform less 13"

D.B.G. (Distance Between Guides)
 Platform width plus 4"

HOLELESS AND OVERHEAD TRACTION FREIGHT CARS ALSO AVAILABLE

Contact your Delaware Elevator Manufacturing representative to discuss your specific requirements

OVERHEAD AND PIT DEPTH QUICK CALCULATION

- Minimum overhead using single-section car gate = Cab height + (car gate height of 6'-0") + 6"
- Minimum pit depth using vertical bi-parting freight doors = 1/2 door height + 6"
- For seismic zone 2 or greater application - increase hoistway width 2"
- For 1 1/4" running clearance, increase hoistway depth 1/2"

Hoistway dimensions shown are not for final construction purposes. National & Local code years and variations may affect sizes shown. All dimensions should be verified with DEM Elevating Equipment prior to construction.

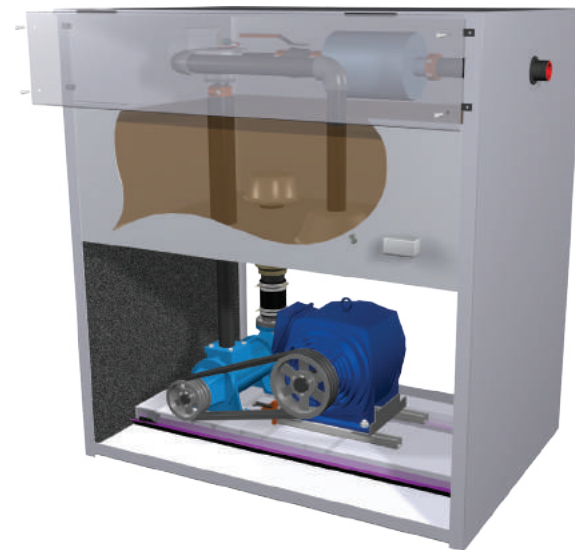
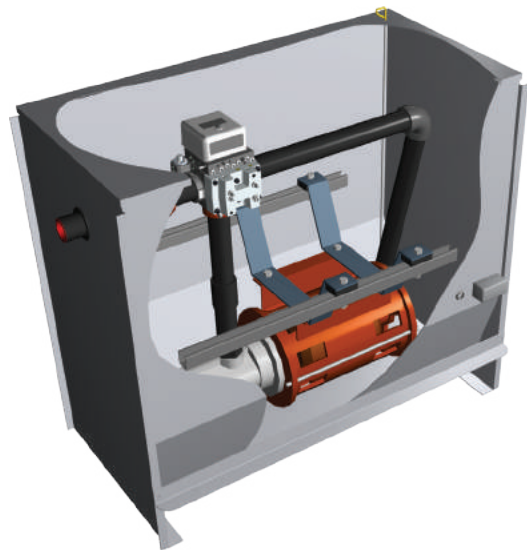

Submersible Power Units

Standard Equipment

- Motors: 15-50HP 3PH
- IMO Pumps: 24-253 GPM
- Maxton Valve Standard (Mounted Inside the Tank)
- 12 ga. Enamel Tank
- Isolated Anchoring Feet
- Noise Reducing Muffler
- Oil Level Dip Stick
- Isolated Pump/Motor Suspension for Easy Removal & Quiet Operation
- Protective Packaging on a Pallet
- Standard Size: 51" W x 42" H x 22" D

Options

- EECO Valve
- Bucher Valve
- Blain Valve
- Constant Down Speed Valves
- Custom Tank Sizes
- Low Pressure Switch
- Low Oil Switch
- Tank Heater
- Oil Cooler
- Oil Level Sight Gauge
- Shut Off (Ball) Valve
- Oil Return Pump
- DEM EE can meet your custom needs; call if requested options are not listed above.

Belt Driven Power Units

Standard Equipment

- Motors: 15-100HP 3PH
- IMO Pumps: 43-425 GPM Single Pump
- Transferable Oil up to 250 Gal.
- Tandem Pumps/Motors up to 200HP/850GPM
- Maxton Valve Standard
- Valve Mounted in the Tank for Easy Stand-up Adjusting
- 12 ga. Formed Tank & Body
- Effective Easy Belt Adjustment
- Noise Reducing Muffler
- Isolated Pump/Motor Bedplate
- Protective Packaging
- Shut Off (Ball) Valve in the Tank
- Oil Level Sight Gauge
- Drip Pan

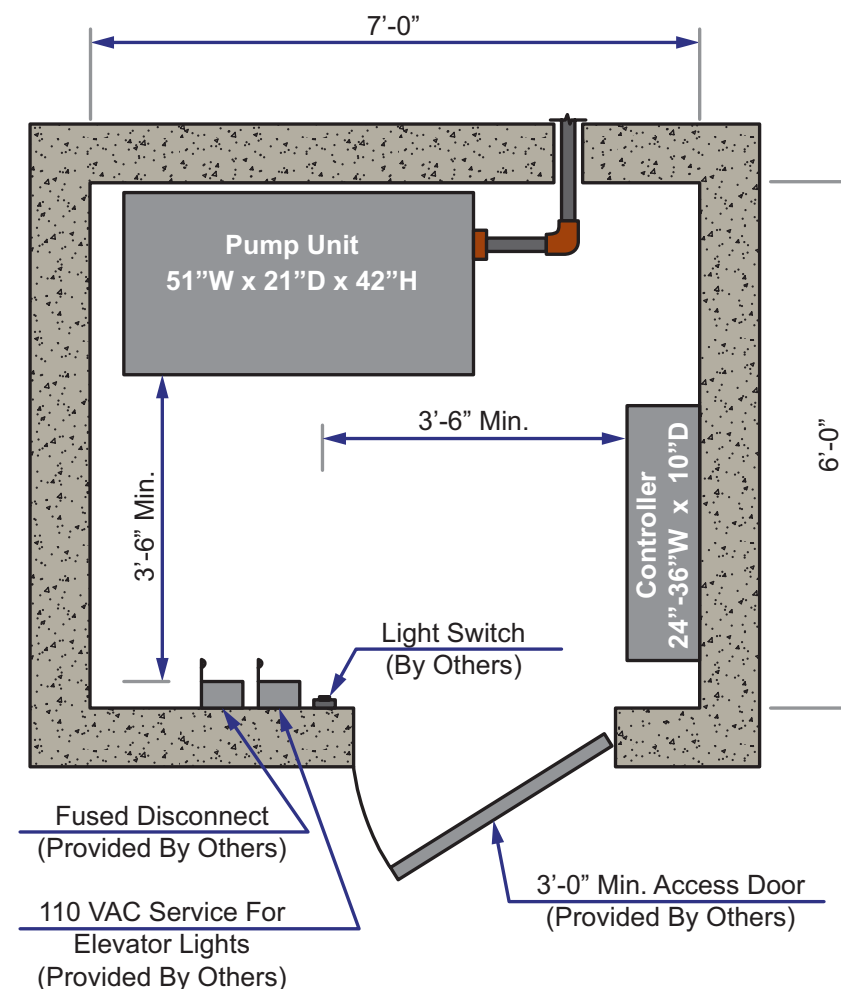

Notes:

- Provide a legally constructed and enclosed machine room, adequately lighted, and conditioned to maintain temperature between 60° to 90° Fahrenheit, relative humidity is not to exceed 90% non-condensing.
- Machine room must be of adequate size to provide clearances around and between equipment as required by code.
- Provide a fused disconnect switch for each elevator in the machine room, located in a position based on local code and within sight of elevator equipment, and arranged to be locked in the off position.
- Provide 110 VAC service for elevator light and accessories connected to the car light service terminal on the elevator controller. A single disconnecting means for the car light and accessories shall be located in the machine room and arranged to be locked in the open position.
- Provide light, switch and 110 VAC GFI outlet in the machine room, with switch located adjacent to the machine room door.
- Only elevator related equipment is allowed in machine room.

Electrical Data for Hydraulic 3 Phase Motors (80 Starts Per Hour) in a Submersible Power Unit			
HP	VOLT	Full Load Amps	Locked Rotor Amps (Wye-Delta)
15	208	51	82
15	230/460	45/22.5	68/34
20	208	66	104
20	230/460	56/28	90/45
25	208	78	130
25	230/460	68/34	113/57
30	208	90	157
30	230/460	78/39	136/68
40	208	120	224
40	230/460	104/52	195/97
50	208	142	307
50	230/460	123/62	268/133

Locked Rotor AMPS are given for Wye-Delta starting. Starting AMPS are 3 times Locked Rotor AMPS when starting across the line.

Machine room size as shown is minimum, other sizes and shapes can be accommodated.

MRL CAR TYPE SUMMARY

The group one "Machine Room Less" is an engineered package design that utilizes an efficient, gearless, permanent magnet machine. This machine, with all the related traction components, is installed inside the hoistway eliminating the need for a machine room.

- Engineering support and service
- Shop drawings and group one installation drawings
- Consolidated shipments available when complete packages are ordered

Advantages for the Building Owner

- Saves on valuable floor space
- No contamination to the ground such as on hydraulic applications
- Greater power efficiency
- Superior performance and ride quality
- Reduction on the elevator power feeder

Equipment Included

- Gearless MRL PM machine
- Governor and tail sheave
- Factory pre-assembled overhead machine frame
- Counterweight frame and weights
- Car & cwt roller guides with mounting plates
- Sling including: Crosshead, stiles, bolsters, brace rods, strike plates
- Platform with toe guard
- Buffer stands, spring or oil buffers
- Safeties
- Underslung assembly with deflector sheaves
- Guide rails, rail brackets with spreader plates, clips and fasteners
- Car & cwt ropes and wedge sockets
- Limit switches, mounting brackets & cam
- All hardware included in labeled bags

Equipment Capabilities

- Passenger & service cars
- Capacities from 2,100 lbs up to 3,500 lbs
- Speeds from 100 FPM up to 350 FPM
- Travel up to 50'-0"

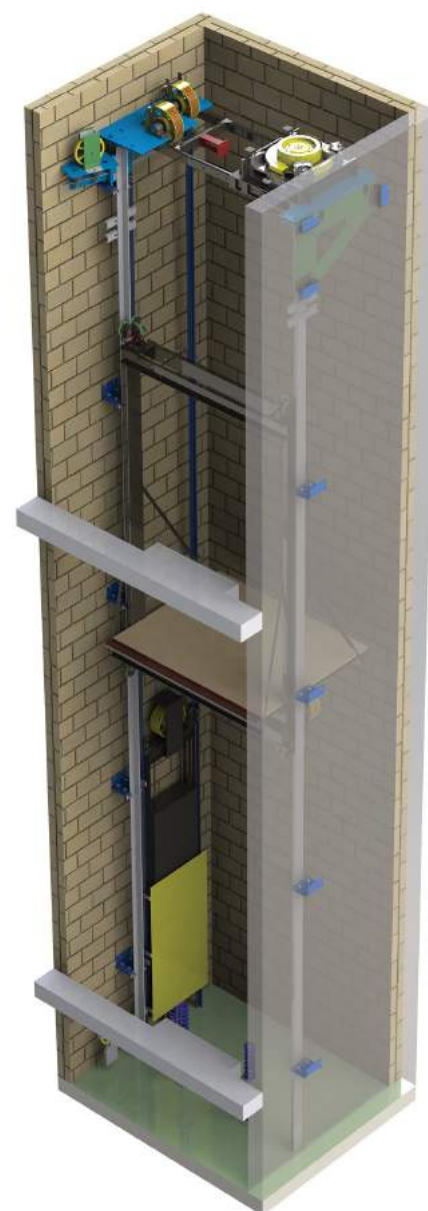

MRL Front Opening Dimensions

Capacity (lbs.)	Platform W x D (min)	Hoistway W x D (min)	Clear Opening	Clear Inside W x D (min)	SSSO Door	SSCO Door	2SSO Door
P2100-FO	6'-0" x 5'-1"	7'-8" x 5'-10"	3'-0"	5'-8" x 4'-3"	X		
P2500-FO	7'-0" x 5'-1"	8'-8" x 5'-10"	3'-6"	6'-8" x 4'-3"	X	X	
P3000-FO	7'-0" x 5'-6"	8'-8" x 6'-3"	3'-6"	6'-8" x 4'-8"	X	X	
P3500-FO	7'-0" x 6'-3"	8'-8" x 7'-0"	3'-6"	6'-8" x 5'-5"	X	X	

MRL Front & Rear Opening Dimensions

Capacity (lbs.)	Platform W x D (min)	Hoistway W x D (min)	Clear Opening	Clear Inside W x D (min)	SSSO Door	SSCO Door	2SSO Door
P2100-FR	6'-0" x 5'-8"	7'-8" x 6'-8 1/2"	3'-0"	5'-8" x 4'-4"	X		
P2500-FR	7'-0" x 5'-8"	8'-8" x 6'-8 1/2"	3'-6"	6'-8" x 4'-4"	X	X	
P3000-FR	7'-0" x 5'-11"	8'-8" x 6'-11 1/2"	3'-6"	6'-8" x 4'-7"	X	X	
P3500-FR	7'-0" x 6'-9"	8'-8" x 7'-9 1/2"	3'-6"	6'-8" x 5'-5"	X	X	

- Hoistway dimensions are minimum clear inside requirements. Shorter installation times can be obtained by increasing these dimensions by up to 2". **For seismic zone 2 and up, add 2" to hoistway width to comply with Code requirements.** Due to space limitations Rail Supported Elevators use compensation chain to avoid use of the counterweight guard.
- Use of 8mm and 10mm ropes for traction elevators was approved by ASME A17.6 - effective 1st July 2010.
- New York City Building Department has issued new rules governing the overhead requirements for MRLs. Please contact a DEM Elevating Equipment representative.
- Dimensions shown here are for reference only, consult your sales representative for final dimensions for your particular project.
- Hoistway depth dimensions based on 8# cwt rails, if using 15# cwt rails, add 4" to hoistway depth.

Pit and Overhead Minimum Requirements For Cars With 8'-0 Cab Height

Speed	P2100,P2500,P3000,P3500	
	Pit	O.H.
100 FPM*	5'-0"	14'-6"/14'-0"
150 FPM*	5'-0"	14'-7"/14'-0"
200 FPM*	5'-0"	14'-9"/14'-1"
250 FPM**	5'-6"	15'-0"/14'-6"
300 FPM**	5'-6"	15'-1"/14'-7"
350 FPM**	5'-6"	15'-4"/14'-10"

Rail Supported MRL designed with Torin TPM series machine.

*Spring buffers for car and counterweight / **Oil buffers for car and counterweight. Based on ASME A17.1

O.H. Left column has spring or oil buffers with 6" Runby / Right Column has all oil buffers with 0" Runby.

Note: For cars with tall cabs add 1" to O.H. for every inch of cab height added.

For custom dimensions, contact a DEM Elevating Equipment representative.

Hoistway dimensions shown are not for final construction purposes. National & Local code years and variations may affect sizes shown. All dimensions should be verified with DEM Elevating Equipment prior to construction.

MRL CAR TYPE SUMMARY

The group one "Machine Room Less" is an engineered package design that utilizes an efficient, gearless, permanent magnet machine. This machine, with all the related traction components, is installed inside the hoistway eliminating the need for a machine room.

- Engineering support and service
- Shop drawings and group one installation drawings
- Consolidated shipments available when complete packages are ordered

Advantages for the Building Owner

- Saves on valuable floor space
- No contamination to the ground such as on hydraulic applications
- Greater power efficiency
- Superior performance and ride quality
- Reduction on the elevator power feeder

Equipment Included

- Gearless MRL PM machine
- Governor and tail sheave
- Overhead beams, machine bedplate, hitch plates, governor plate
- Factory pre-assembled overhead machine frame
- Counterweight frame and weights
- Car & cwt roller guides with mounting plates
- Sling including: Crosshead, stiles, bolsters, brace rods, strike plates
- Platform with toe guard
- Buffer stands, spring or oil buffers
- Safeties
- Underslung assembly with deflector sheaves
- Guide rails, rail brackets with spreader plates, clips and fasteners
- Car & cwt ropes and wedge sockets
- Limit switches, mounting brackets & cam
- All hardware included in labeled bags

Equipment Capabilities

- Passenger & service cars
- Capacities from 2,100 lbs up to 3,500 lbs
- Speeds from 100 FPM up to 350 FPM
- Travels up to 200'
- For Frame Building Supported design machine beam pockets are required in the hoistway walls

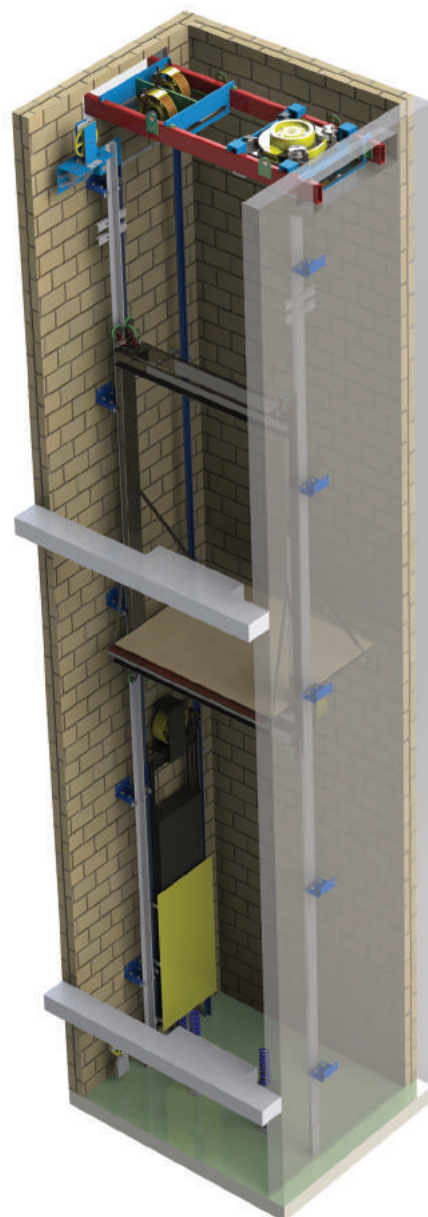

MRL Front Opening Dimensions

Capacity (lbs.)	Platform W x D (min)	Hoistway W x D (min)	Clear Opening	Clear Inside W x D (min)	SSSO Door	SSCO Door	2SSO Door
P2100-FO	6'-0" x 5'-1"	7'-8" x 5'-10"	3'-0"	5'-8" x 4'-3"	X		
P2500-FO	7'-0" x 5'-1"	8'-8" x 5'-10"	3'-6"	6'-8" x 4'-3"	X	X	
P3000-FO	7'-0" x 5'-6"	8'-8" x 6'-3"	3'-6"	6'-8" x 4'-8"	X	X	
P3500-FO	7'-0" x 6'-3"	8'-8" x 7'-0"	3'-6"	6'-8" x 5'-5"	X	X	

MRL Front & Rear Opening Dimensions

Capacity (lbs.)	Platform W x D (min)	Hoistway W x D (min)	Clear Opening	Clear Inside W x D (min)	SSSO Door	SSCO Door	2SSO Door
P2100-FR	6'-0" x 5'-8"	7'-8" x 6'-8 1/2"	3'-0"	5'-8" x 4'-4"	X		
P2500-FR	7'-0" x 5'-8"	8'-8" x 6'-8 1/2"	3'-6"	6'-8" x 4'-4"	X	X	
P3000-FR	7'-0" x 5'-11"	8'-8" x 6'-11 1/2"	3'-6"	6'-8" x 4'-7"	X	X	
P3500-FR	7'-0" x 6'-9"	8'-8" x 7'-9 1/2"	3'-6"	6'-8" x 5'-5"	X	X	

- Hoistway dimensions are minimum clear inside requirements. Shorter installation times can be obtained by increasing these dimensions by up to 2". **For seismic zone 2 and up, add 2" to hoistway width to comply with Code requirements.** Due to space limitations Frame Building Supported Elevators use compensation chain to avoid use of the counterweight guard.
- Use of 8mm and 10mm ropes for traction elevators was approved by ASME A17.6 - effective 1st July 2010.
- New York City Building Department has issued new rules governing the overhead requirements for MRLs. Please contact a DEM Elevating Equipment representative.
- Dimensions shown here are for reference only, consult your sales representative for final dimensions for your particular project.
- Hoistway depth dimensions based on 8# cwt rails, if using 15# cwt rails, add 4" to hoistway depth.

Pit and Overhead Minimum Requirements For Cars With 8'-0 Cab Height		
Speed	P2100, P2500,P3000,P3500	
	Pit	O.H.
100 FPM*	5'-0"	14'-5"/13'-11"
150 FPM*	5'-0"	14'-6"/13'-11"
200 FPM*	5'-0"	14'-8"/14'-0"
250 FPM**	5'-6"	14'-11"/14'-5"
300 FPM**	5'-6"	15'-0"/14'-6"
350 FPM**	5'-6"	15'-3"/14'-9"

Frame Building Supported MRL design with Torin TPM series machine.
 *Spring buffers for car and counterweight / **Oil buffers for car and counterweight. Based on ASME A17.1
 O.H. Left column has spring or oil buffers with 6" Runby / Right Column has all oil buffers with 0" Runby.

Note: For cars with tall cabs add 1" to O.H. for every inch of cab height added.

For custom dimensions, contact a DEM Elevating Equipment representative.

Hoistway dimensions shown are not for final construction purposes. National & Local code years and variations may affect sizes shown. All dimensions should be verified with DEM Elevating Equipment prior to construction.

MRL CAR TYPE SUMMARY

The group one "Machine Room Less" is an engineered package design that utilizes an efficient, gearless, permanent magnet machine. This machine, with all the related traction components, is installed inside the hoistway eliminating the need for a machine room.

- Engineering support and service
- Shop drawings and group one installation drawings
- Consolidated shipments available when complete packages are ordered

Advantages for the Building Owner

- Saves on valuable floor space
- No contamination to the ground such as on hydraulic applications
- Greater power efficiency
- Superior performance and ride quality
- Reduction on the elevator power feeder

Equipment Included

- Gearless MRL PM machine
- Governor and tail sheave
- Overhead beams, machine bedplate, hitch plates, governor plate
- Factory pre-assembled overhead machine frame
- Counterweight frame and weights
- Car & cwt roller guides with mounting plates
- Sling including: Crosshead, stiles, bolsters, brace rods, strike plates
- Platform with toe guard
- Buffer stands, spring or oil buffers
- Safeties
- Underslung assembly with deflector sheaves
- Guide rails, rail brackets with spreader plates, clips and fasteners
- Car & cwt ropes and wedge sockets
- Limit switches, mounting brackets & cam
- All hardware included in labeled bags

Equipment Capabilities

- Passenger & service cars
- Capacities from 2,100 lbs up to 5,000 lbs
- Speeds from 100 FPM up to 500 FPM
- Travels up to 300'
- For Building Supported design machine beam pockets are required in the hoistway walls

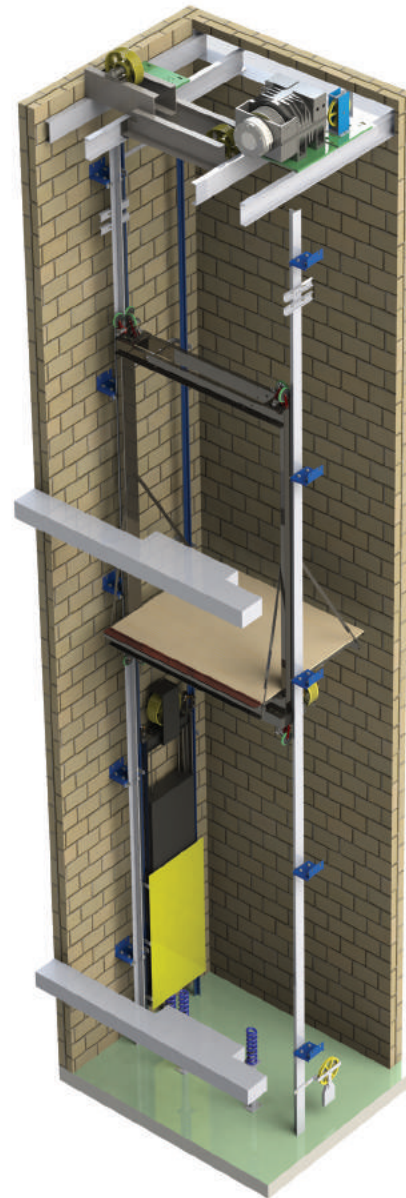

MRL Front Opening Dimensions

Capacity (lbs.)	Hoistway W x D (min)	Platform W x D (min)	Clear Inside W x D (min)	Clear Opening	SSSO Door	SSCO Door	2SSO Door
P2100-FO	7'-6" x 6'-5"	6'-0" x 5'-1"	5'-8" x 4'-3"	3'-0"	X		
P2500-FO	8'-6" x 6'-6 1/2"	7'-0" x 5'-1"	6'-8" x 4'-3"	3'-6"	X	X	
P3000-FO	8'-6" x 6'-8"	7'-0" x 5'-6"	6'-8" x 4'-8"	3'-6"	X	X	
P3500-FO	8'-6" x 7'-2"	7'-0" x 6'-3"	6'-8" x 5'-5"	3'-6"	X	X	
P4000-FO	9'-7" x 7'-2"	8'-0" x 6'-3"	7'-8" x 5'-5"	3'-0" 4'-0"	X	X X	
S3500-FO	6'-10" x 9'-3"	5'-4" x 8'-4"	5'-0" x 7'-4"	3'-6"			X
S4000-FO	7'-6" x 9'-3"	6'-0" x 8'-5"	5'-8" x 7'-5"	4'-0"			X
S4500-FO	7'-6" x 9'-7"	6'-0" x 8'-9"	5'-8" x 7'-9"	4'-0"			X
S5000-FO	7'-6" x 10'-6"	6'-0" x 9'-8"	5'-8" x 8'-8"	4'-0"			X

MRL Front & Rear Opening Dimensions

(* See Frame Building Supported dimensions.)

Capacity (lbs.)	Hoistway W x D (min)	Platform W x D (min)	Clear Inside W x D (min)	Clear Opening	SSSO Door	SSCO Door	2SSO Door
P2100-FR (*)	7'-6" x 6'-8 1/2"	6'-0" x 5'-8"	5'-8" x 4'-4"	3'-0"	X		
P2500-FR (*)	8'-6" x 6'-8 1/2"	7'-0" x 5'-8"	6'-8" x 4'-4"	3'-6"	X	X	
P3000-FR	8'-6" x 7'-5 1/2"	7'-0" x 6'-5"	6'-8" x 5'-1"	3'-6"	X	X	
P3500-FR	8'-10" x 7'-9 1/2"	7'-0" x 6'-9"	6'-8" x 5'-5"	3'-6"	X	X	
P4000-FR	9'-11" x 7'-9 1/2"	8'-0" x 6'-9"	7'-8" x 5'-5"	3'-0" 4'-0"	X	X X	
S3500-FR	6'-10" x 10'-3 1/2"	5'-4" x 9'-0"	5'-0" x 7'-4"	3'-6"			X
S4000-FR	7'-6" x 10'-4 1/2"	6'-0" x 9'-1"	5'-8" x 7'-5"	4'-0"			X
S4500-FR	7'-6" x 10'-9 1/2"	6'-0" x 9'-6"	5'-8" x 7'-10"	4'-0"			X
S5000-FR	7'-6" x 11'-7 1/2"	6'-0" x 10'-4"	5'-8" x 8'-8"	4'-0"			X

- Hoistway dimensions are minimum clear inside requirements. Shorter installation times can be obtained by increasing these dimensions by up to 2". **For seismic zone 2 and up, add 2" to hoistway width to comply with Code requirements.** Due to space limitations Rail Supported Elevators use compensation chain to avoid use of the counterweight guard.
- Use of 8mm and 10mm ropes for traction elevators was approved by ASME A17.6 - effective 1st July 2010.
- New York City Building Department has issued new rules governing the overhead requirements for MRLs. Please contact a DEM Elevating Equipment representative.
- Dimensions shown here are for reference only, consult your sales representative for final dimensions for your particular project.
- Hoistway depth dimensions based on 8# cwt rails, if using 15# cwt rails, add 4" to hoistway depth.

Pit and Overhead Minimum Requirements For Cars With 8'-0" Cab Height

Speed	P2100,P2500,P3000,P3500		P4000, S4000, S4500, S5000	
	Pit	O.H.	Pit	O.H.
100 FPM*	5'-0"	16'-4"/15'-10"	5'-0"	15'-9"/15'-3"
150 FPM*	5'-0"	16'-5"/15'-11"	5'-0"	15'-10"/15'-3"
200 FPM*	5'-0"	16'-7"/15'-11"	5'-0"	16'-0"/15'-4"
250 FPM**	5'-6"	16'-10"/16'-4"	5'-6"	16'-3"/15'-9"
300 FPM**	5'-6"	16'-11"/16'-5"	5'-6"	16'-4"/15'-10"
350 FPM**	5'-6"	17'-2"/16'-8"	5'-6"	16'-7"/16'-1"
400 FPM**	5'-9"	16'-10"/16'-4"	6'-0"	16'-10"/16'-4"
450 FPM**	6'-3"	17'-5"/16'-11"	6'-6"	17'-5"/16'-11"
500 FPM**	6'-3"	17'-7"/17'-1"	6'-6"	17'-7"/17'-1"

*Spring buffers for car and counterweight / **Oil buffers for car and counterweight.
Note: For cars with tall cabs add 1" to O.H. for every inch of cab height added.

O.H. Left column has spring or oil buffers with 6" Runby / Right Column has all oil buffers with 0" Runby.

For custom dimensions, contact a DEM Elevating Equipment representative.

Hoistway dimensions shown are not for final construction purposes. National & Local code years and variations may affect sizes shown. All dimensions should be verified with DEM Elevating Equipment prior to construction.

MRL CAR TYPE SUMMARY

The group one "Machine Room Less" is an engineered package design that utilizes an efficient, gearless, permanent magnet machine. This machine, with all the related traction components, is installed inside the hoistway eliminating the need for a machine room.

- Engineering support and service
- Shop drawings and group one installation drawings
- Consolidated shipments available when complete packages are ordered

Advantages for the Building Owner

- Saves on valuable floor space
- No contamination to the ground such as on hydraulic applications
- Greater power efficiency
- Superior performance and ride quality
- Reduction on the elevator power feeder

Equipment Included

- Gearless MRL PM machine
- Governor and tail sheave
- Overhead beams, machine bedplate, hitch plates, governor plate
- Factory pre-assembled overhead machine frame
- Counterweight frame and weights
- Car & cwt roller guides with mounting plates
- Sling including: Crosshead, stiles, bolsters, brace rods, strike plates
- Platform with toe guard
- Buffer stands, spring or oil buffers
- Safeties
- Underslung assembly with deflector sheaves
- Guide rails, rail brackets with spreader plates, clips and fasteners
- Car & cwt ropes and wedge sockets
- Limit switches, mounting brackets & cam
- All hardware included in labeled bags

Equipment Capabilities

- Passenger & service cars
- Capacities from 2,100 lbs up to 5,000 lbs
- Speeds from 100 FPM up to 500 FPM
- Travels up to 300'
- For Corner posts and Overslung Traction design machine beam pockets are required in the hoistway walls

**NEED SOMETHING CUSTOM?**

DEM Elevating Equipment specializes in custom vertical transportation equipment. We offer nonproprietary elevators with no limitations and the utmost quality control.

**** ALL OVERSLUNG/CORNERPOST MRL'S ARE CUSTOM MADE ACCORDING TO YOUR SPECS ****

Notes:

- Provide a legally constructed and enclosed control room, adequately lighted, and conditioned to maintain temperature between 60° to 90° Fahrenheit, relative humidity is not to exceed 90% non-condensing.
- Control room must be of adequate size to provide clearances around and between equipment as required by code.
- Provide a fused disconnect switch for each elevator in the control room, located in a position based on local code and within sight of elevator equipment, and arranged to be locked in the off position.
- Provide 110 VAC service for elevator light and accessories connected to the car light service terminal on the elevator controller.
- A single disconnecting means for the car light and accessories shall be located in the control room and arranged to be locked in the open position.
- Provide light, switch and 110 VAC GFI outlet in the control room, with switch located adjacent to the door.
- Only elevator related equipment is allowed inside the control room.
- Dimensional data shown above may vary from National Codes to Local Codes.
- For Duplex or Triplex applications control rooms will have different dimensions. Consult your sales representative.
- When special equipment is required, as transformers, brake resistors, etc sizes of control room will increase to accommodate the equipment and have the required clearances. This factor determines the Small / Large size of the Control Room.
- Transformers, resistor boxes and similar equipment are required to have 6" clearances on all sides.
- NEC work space minimum clear distances vary from 3 to 4 feet depending on nominal voltage and mounted electrical equipment condition, consult your AHJ.
- The preferred location of the Control Room is adjacent to the hoist way on the top floor, but other locations could be used.
- The linear maximum run of the encoder communication cable is 160 ft., from the machine to the controller.

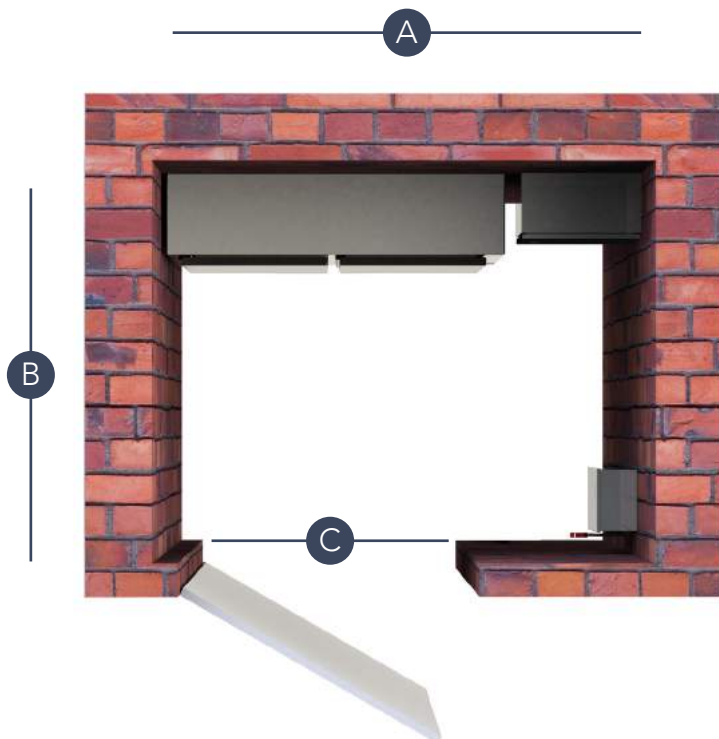

	A	B	C
Large	5'-6"	6'-4"	3'-0"
Small	5'-0"	5'-11"	3'-0"
(INSIDE MINIMUM DIMENSIONS)			

Governor Access:

- Determine if your local code allows remote reset governor, if not an access up on the overhead must be provided to inspect and reset the governor. If it is not possible to provide an access up on the overhead, an option will be the use of a Delaware Elevator Manufacturing pit mounted governor.

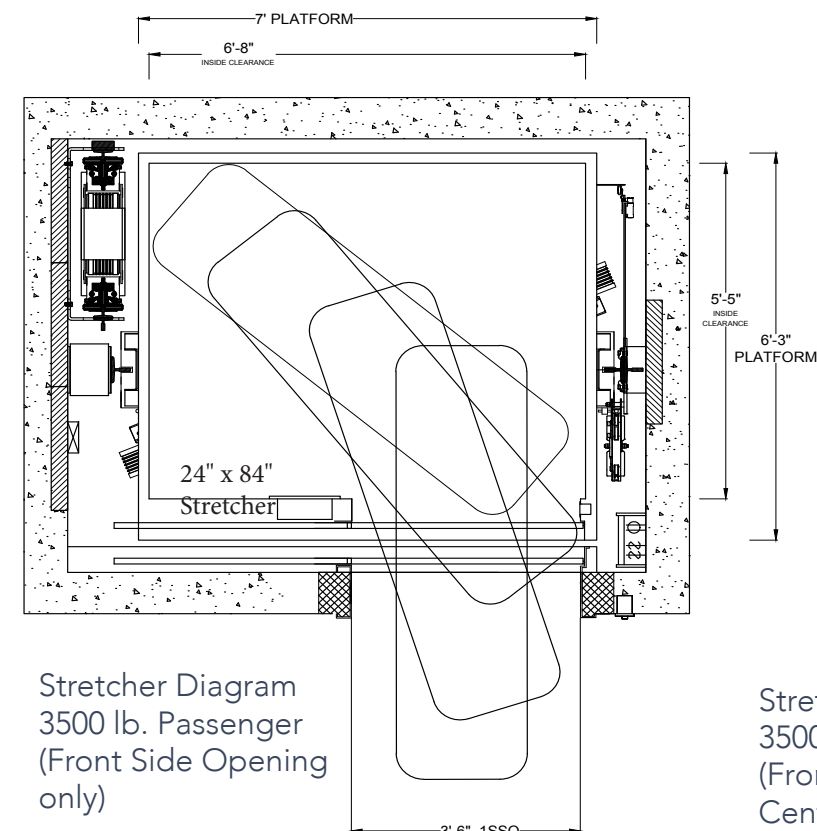

Stretcher Diagram
3500 lb. Passenger
(Front Side Opening
only)

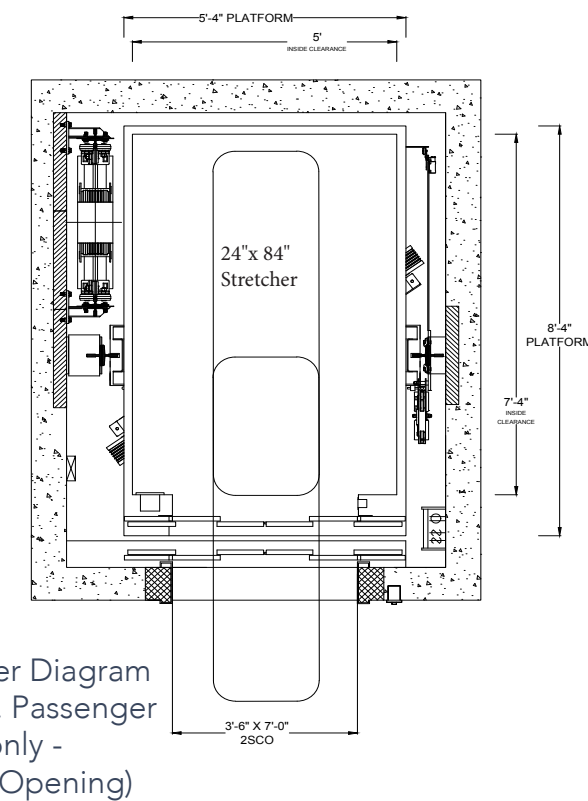

Stretcher Diagram
3500 lb. Passenger
(Front only -
Center Opening)

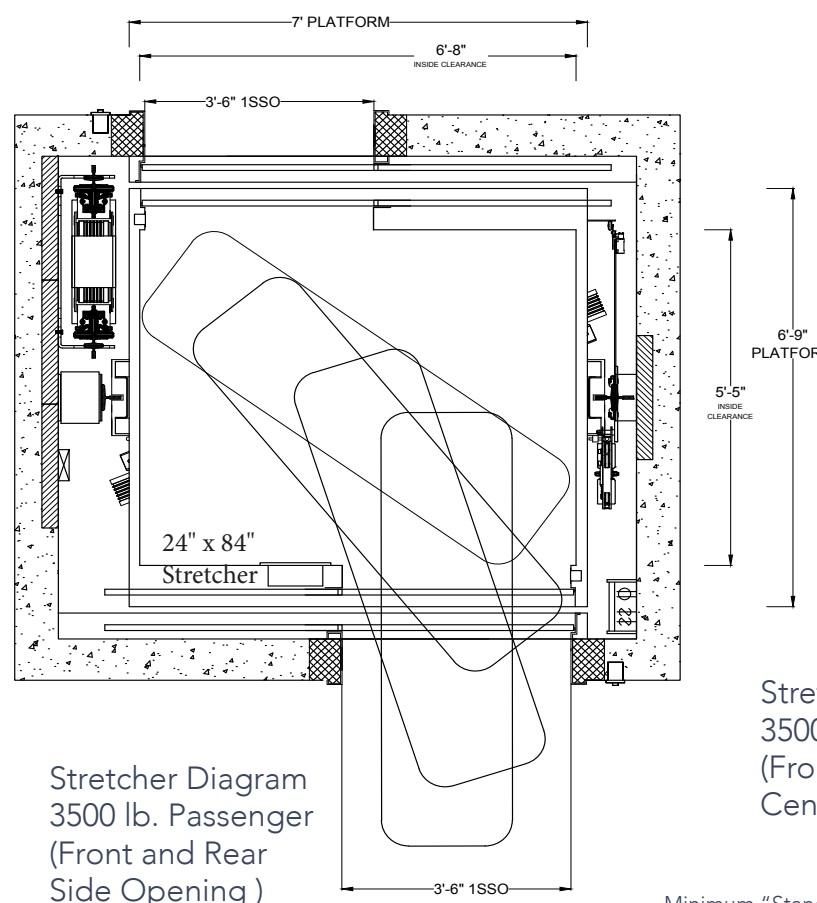

Stretcher Diagram
3500 lb. Passenger
(Front and Rear
Side Opening)

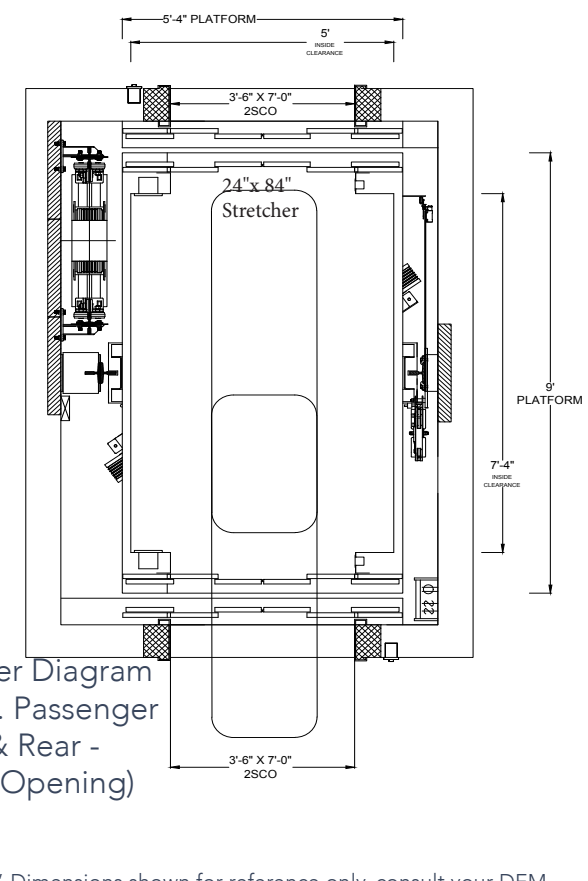

Stretcher Diagram
3500 lb. Passenger
(Front & Rear -
Center Opening)

Minimum "Standard" Dimensions shown for reference only, consult your DEM Elevating Equipment Sales Representative to discuss your particular project.



OHT CAR TYPE SUMMARY

This design utilizes a geared or gearless traction machine, along with the controller and governor, mounted in a penthouse machine room directly over (above) the hoistway. This application uses hoist ropes and counterweights, to move the car, in lieu of a hydraulic jack. The counterweights can be positioned at the rear of the car (front open only), or at the side of the car. In addition to the main rails, a set of counterweight frame rails are also required.

Advantages

- Much faster speed capability
- Unlimited travel range
- Higher power efficiency than hydraulic car types
- No hydraulic oil being used

Disadvantages

- Substantially higher material cost than hydraulic car types
- Higher field installation cost
- A higher OH is required (typically 16ft) along with a penthouse machine room located over the hoistway

The penthouse machine room can be eliminated by positioning the traction machine next to the side of the hoistway at one of the landings. This arrangement is referred to as a **basement or offset** machine application. It requires additional hoistway sheaves and machine beam support at the landing location.

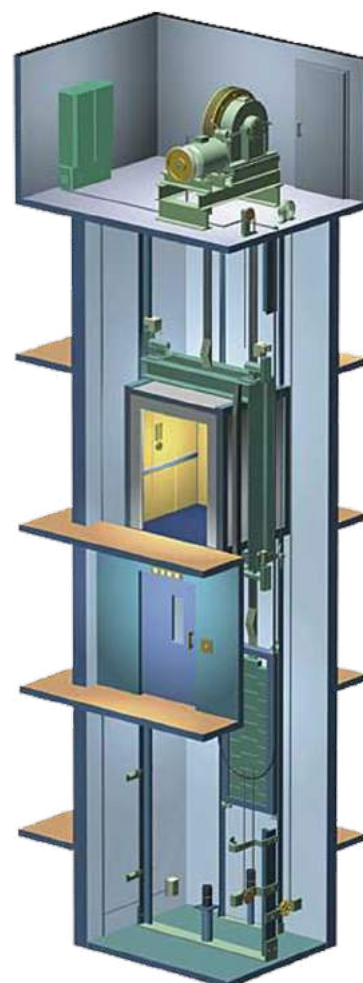

Low Capacity Standard Dimension & Specification Chart

Capacity (lbs.)	Openings F=Front R=Rear	Door Type and Width	Platform Size W x D (min)	Max Speed FPM	Hoistway Size W x D (min)	Clear Inside W x D (min)	Minimum Overhead	Minimum Pit Depth
Counterweight at REAR								
2100	F	1SP 36"	6'-0" x 5'-1"	350	7'-4" x 6'-8"	5'-8" x 4'-3"	16'-0"	5'-2"
2500	F	1SP 42"	7'-0" x 5'-1"	350	8'-4" x 6'-8"	6'-8" x 4'-3"	16'-0"	5'-2"
3000	F	1SP 42"	7'-0" x 5'-6"	350	8'-4" x 7'-1"	6'-8" x 4'-8"	16'-0"	5'-2"
3500	F	1SP 42"	7'-0" x 6'-3"	350	8'-4" x 7'-10"	6'-8" x 5'-5"	16'-0"	5'-2"
4000	F	1SP 48"	8'-0" x 6'-3"	350	9'-4" x 7'-10"	7'-8" x 5'-5"	16'-0"	5'-2"
Counterweight at SIDE								
2100	F	1SP 36"	6'-0" x 5'-1"	350	8'-4" x 5'-10"	5'-8" x 4'-3"	16'-0"	5'-2"
2500	F	1SP 42"	7'-0" x 5'-1"	350	9'-4" x 5'-10"	6'-8" x 4'-3"	16'-0"	5'-2"
3000	F	1SP 42"	7'-0" x 5'-6"	350	9'-4" x 6'-3"	6'-8" x 4'-8"	16'-0"	5'-2"
3500	F	1SP 42"	7'-0" x 6'-3"	350	9'-4" x 7'-0"	6'-8" x 5'-5"	16'-0"	5'-2"
3500	F&R	1SP 42"	7'-0" x 6'-9"	350	9'-4" x 7'-9 1/2"	6'-8" x 5'-5"	16'-0"	5'-2"
4000	F	1SP 48"	8'-0" x 6'-3"	350	10'-4" x 7'-0"	7'-8" x 5'-5"	16'-0"	5'-2"
4000	F&R	1SP 48"	8'-0" x 6'-9"	350	10'-4" x 6'-9 1/2"	7'-8" x 5'-5"	16'-0"	5'-2"
3500H	F	2SP 42"	5'-4" x 8'-4"	350	7'-2" x 9'-2"	5'-0" x 7'-4"	16'-0"	5'-2"
3500H	F&R	2SP 42"	5'-4" x 9'-0"	350	7'-2" x 10'-3 1/2"	5'-0" x 7'-4"	16'-0"	5'-2"
4000H	F	2SP 48"	6'-0" x 8'-5"	350	7'-10" x 9'-3"	5'-8" x 7'-5"	16'-0"	5'-2"
4000H	F&R	2SP 48"	6'-0" x 9'-1"	350	7'-10" x 10'-4 1/2"	5'-8" x 7'-5"	16'-0"	5'-2"
4500H	F	2SP 48"	6'-0" x 8'-9"	350	7'-10" x 9'-7"	5'-8" x 7'-9"	16'-0"	5'-2"
4500H	F&R	2SP 48"	6'-0" x 9'-6"	350	7'-10" x 10'-9 1/2"	5'-8" x 7'-10"	16'-0"	5'-2"
5000H	F	2SP 48"	6'-0" x 9'-8"	350	7'-10" x 10'-7"	5'-8" x 8'-8"	16'-6"	5'-2"
5000H	F&R	2SP 48"	6'-0" x 10'-4"	350	7'-10" x 11'-7 1/2"	5'-8" x 8'-8"	16'-6"	5'-2"

Maximum* Inside Net Platform Areas for the Various Rated Loads

Based on car speed of 200 FPM

Cab Height = 8'-0"

For seismic applications add 3" to hoistway width.

Speeds exceeding 200 FPM require additional overhead and pit depth.

Minimum pit depth is based on the use of spring buffers. Add 5" to pit depth if oil buffers are required or car speed exceeds 200 FPM.

225 FPM = add 6" of overhead and 5" of pit depth

250 FPM = add 7" of overhead and 5" of pit depth

300 FPM = add 8" of overhead and 5" of pit depth

350 FPM = add 10" of overhead and 5" of pit depth

*To allow for variations in cab designs, and increase in the maximum inside net platform areas not exceeding 5% shall be permitted for the various rated loads.
General Note: 1 lb. = 0.454 kg - 1 ft² = 0.0929 m²

Hoistway dimensions shown are not for final construction purposes. National & Local code years and variations may affect sizes shown. All dimensions should be verified with DEM Elevating Equipment prior to construction.



STANDARD SPECIFICATIONS

Canopy

- 12 guage steel with white powder coated finish, emergency exit with contact switch, 2 speed fan

Ceiling/Lighting

- Drop ceiling with #4 satin stainless steel frame, with Lexan diffuser panels and fluorescent tube lighting mounted to the underside of the canopy

Cab Front

- #4 satin stainless steel with cutouts for stationary car station and car lantern

Cab Door

- #4 satin stainless steel, 7'-0" high with aluminum sill included

Handrails

- #4 satin stainless steel, (1) at rear wall for front opening, (2) at side walls for front & rear openings

Walls

- Standard 8'-0" high with vents along base, Galvanneal finish shell

Ceiling Options

We offer fluorescent, LED and tamper-proof lighting options in a variety of ceiling materials. Lexan diffusers can also be customized to suit your design needs. Some of our most popular options include:

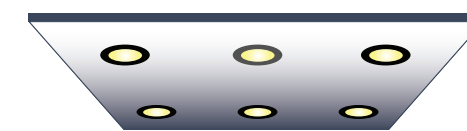

LED downlights recessed in canopy

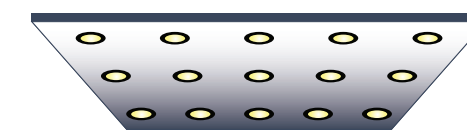

Mini LED downlights recessed in canopy

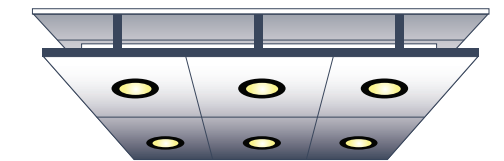

LED downlights in stainless steel drop ceiling

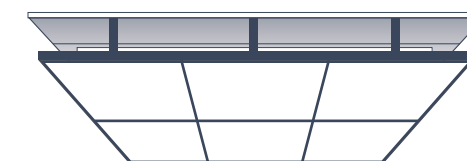

Fluorescent lights with lexan diffusers in drop ceiling

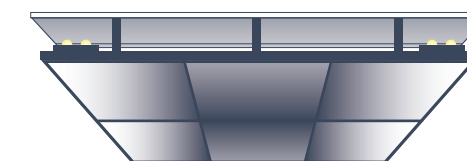

Drop ceiling with perimeter lights

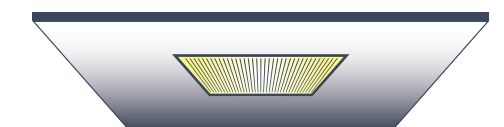

Fluorescent lights recessed in canopy

Handrail Options

Handrails are available in various sizes in both flat and round shapes and come in stainless steel or bronze with satin or mirror finishes.



Flat Handrails with or without returns



Round Handrails with or without returns



Bumper rails

Sill Options

Sills are available in standard aluminum, nickel silver (nickel bronze), yellow bronze or stainless steel





NOTES



ELEVATOR ENTRANCES

At DEM Elevating Equipment, we combine the need to be safe and code compliant with the need to look good and perform reliably, to built some of the most aesthetically pleasing and structurally sound elevator entrances and doors on the market today.

Our entrances come complete with doors, headers, struts, dust covers, z-fascia, sills and all fastening brackets and hardware. They can be fabricated from 14 or 16 gauge material or customized to any thickness required. Our entrances are fire tested and meet or exceed all code requirements. To save you both time and money in the field, our entrances come reinforced, drilled and tapped to your specifications.



Custom Projects

Though our standard products are defined inside this guide, DEM Elevating Equipment is highly capable of adapting our products to non-standard and custom requirements. DEM EE can easily provide custom packages that fit the customers' needs and desires.



Udvar Hazy Center - Air and Space Museum, Washington DC



DEM EE Power Unit



The Washington Monument, Washington DC



Custom Modular Elevator



City Center, Salisbury, MD



Traction MRL - DEI Training Facility



Hotel in Ocean City, MD



Mall, North Miami, FL



Freight Elevator, The National Gallery of Art - Washington, DC



27685 Rockawalkin Ridge Rd.
Salisbury, MD 21801

1-855-890-6603
ManufacturingSales@DEMElevating.com

www.DEMElevating.com